

FREDERICK CROWTHER AND SON LTD

**CROMAR**

EST 1955

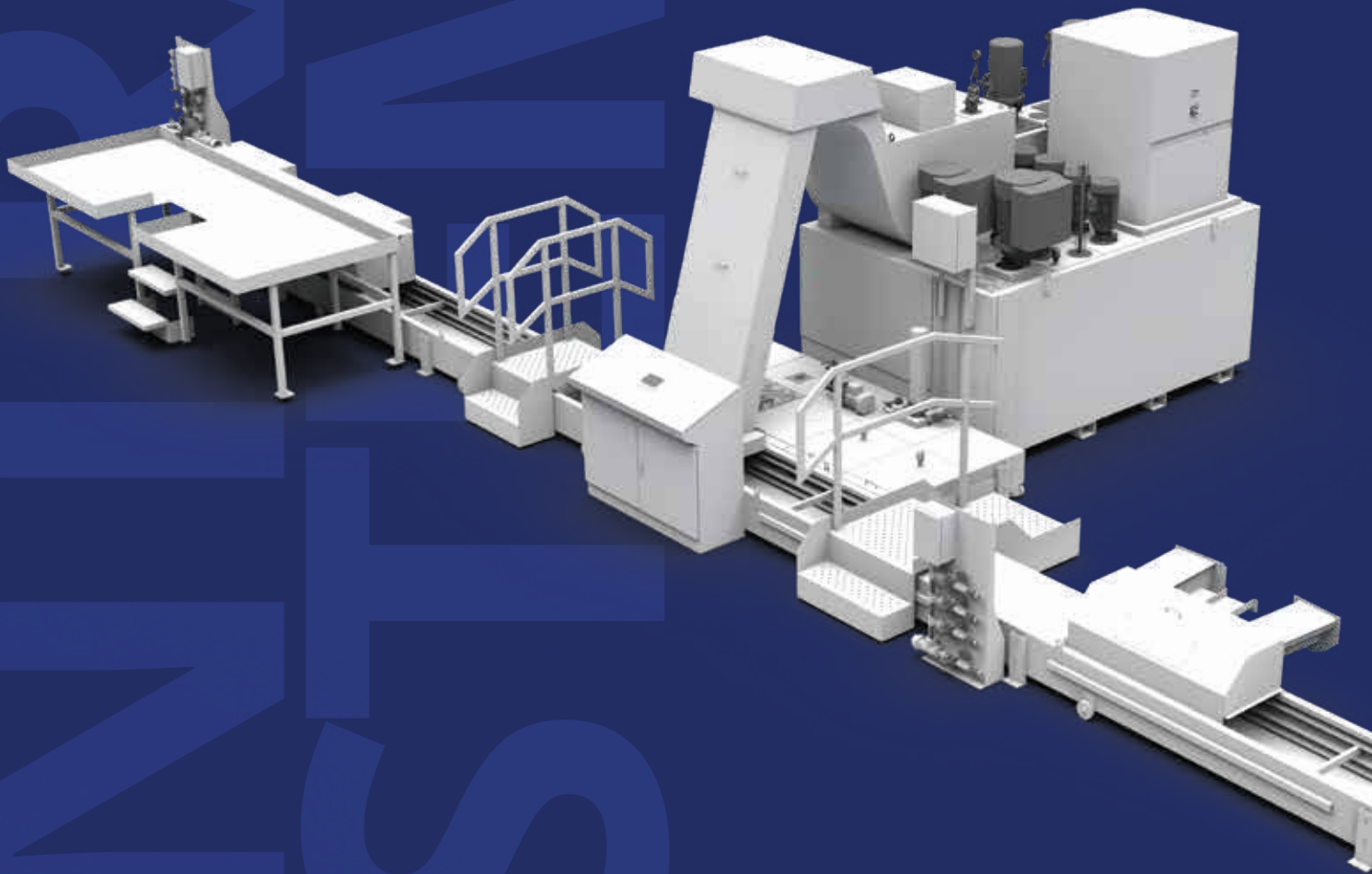

### Advantages

- ✓ Doesn't impose on floor space or obstruct (underground)
- ✓ Tipping bins not required, reduced labour
- ✓ Safety benefits, coolant contained eliminating wet floor hazard
- ...plus many more

## Central Systems

### Swarf Conveyor

These heavy-duty systems are normally designed exclusively to suit unique applications and are the back bone of swarf management systems.

[www.cromar.co.uk](http://www.cromar.co.uk)

## How it works

Central systems, normally designed exclusively to suit bespoke applications manufactured to heavy-duty construction. The type of belt, scraper or slat, is determined by the swarf type. To aid installation and logistics, the system is design into modular sections. These sections are joined by water tight, robust flanges that prevents coolant leakage.

The conveyor(s) can be fed by existing machine tool swarf conveyors, tipping bins or feed conveyors. Often this is conveyed to the discharge point although swarf can complete additional sorting processes beforehand. The whole system can be operated by a PLC controller which has excellent usability.

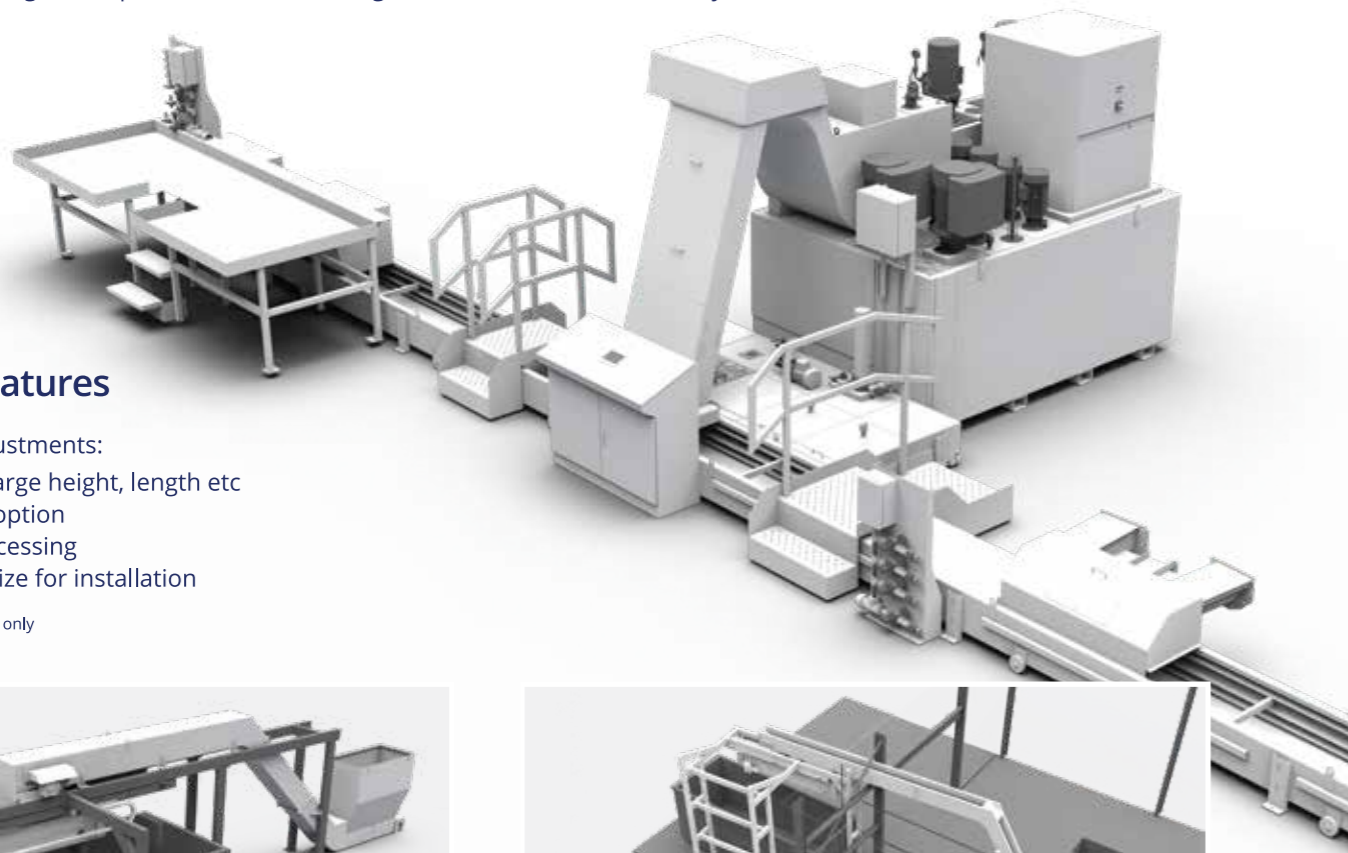

## Adjustable Features

1. Multiple form adjustments:  
Case width, discharge height, length etc
2. Customer colour option
3. Further swarf processing
4. Modular section size for installation

Image for illustration purposes only

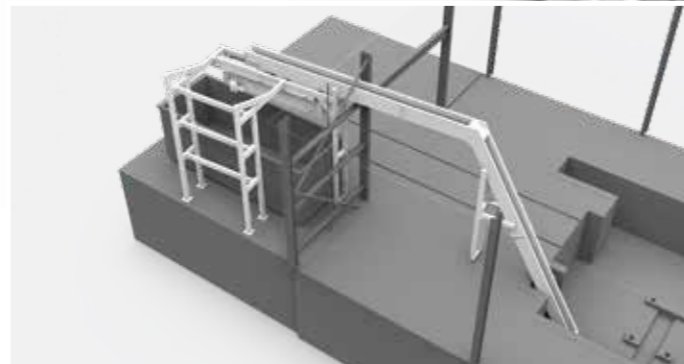
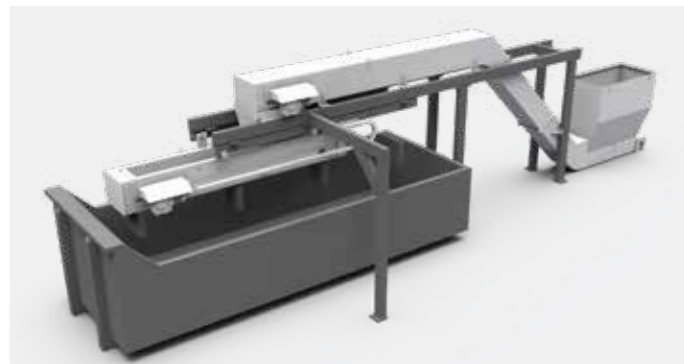

## Features and Benefits

- ✓ Optimise floor space (underground)
- ✓ Tipping bins not required, reduced labour
- ✓ Safety benefits, coolant contained eliminating wet floor hazard
- ✓ Fully automated allowing continual running
- ✓ Handles high volumes of swarf
- ✓ Reliable due to heavy duty construction, built to last
- ✓ Integrates stages of swarf processing

## Principal Applications

- ✓ Large production facilities with multiple machines
- ✓ Underground operations
- ✓ Raised operations
- ✓ Wet and dry processing
- ✓ Floor mounted collection of swarf
- ✓ Central swarf handling/processing

## Optional Equipment



Discharge reciprocation

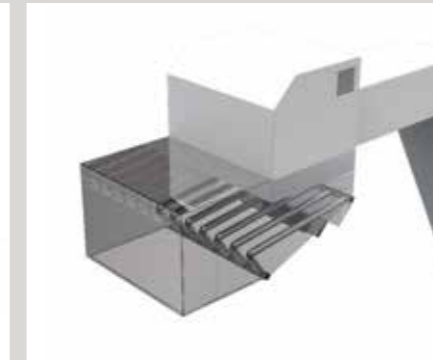

Bar end separator

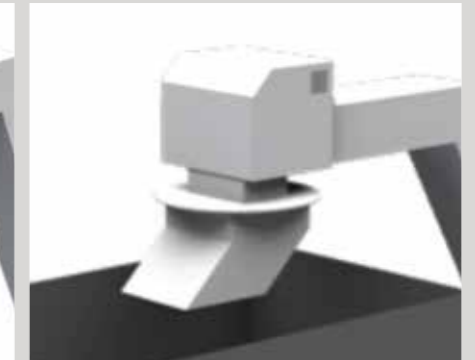

Swivel chute

We understand most machine applications are different. To which we offer bespoke design options and equipment to suit your needs. With the nature of central systems being bespoke, we have a design department to liaise with customers to ensure the best possible solution is produced.

## Suitable Swarf Types

Suitable for handling the below swarf types:



Stringy Swarf



Mixed Swarf



Small Chipped Swarf



Fine Swarf



Ultra Fine Swarf

FREDERICK CROWTHER AND SON LTD



EST 1955

**Frederick Crowther & Son Ltd**

Locksley Works,  
Armytage Road Industrial Estate,  
Armytage Road, Brighouse,  
West Yorkshire, HD6 1QF  
Tel: +44 (0) 1484 400200

**Cromar Metal Products Ltd**

Unit 2 & 3 Guards Road  
Industrial Estate,  
Guards Road,  
Coldstream, TD12 4EE  
Tel: +44 (0) 1890 883139

[www.cromar.co.uk](http://www.cromar.co.uk)

[sales@cromar.co.uk](mailto:sales@cromar.co.uk)